

Ø 240 x Ø 6,5 x 6 Halat

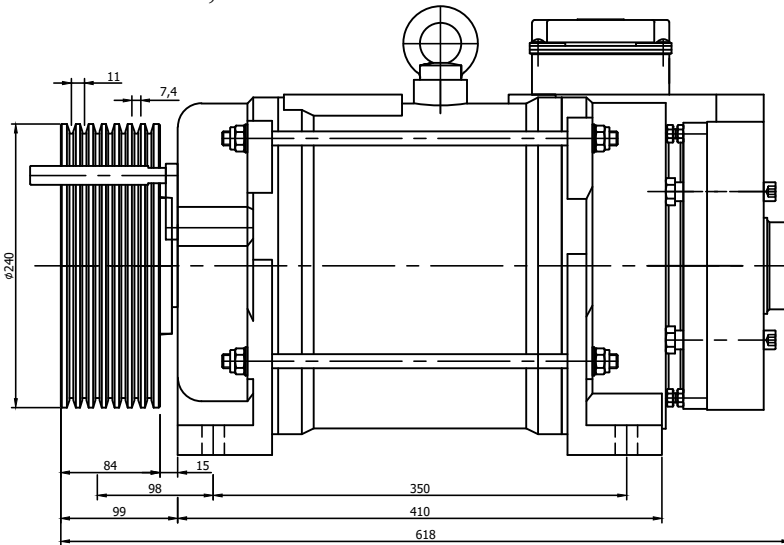

Ø 240 x Ø 6,5 x 7 Halat

**NMF.275 - MANYETİK FRENİN ÖZELLİKLERİ**

|               |   |          |         |
|---------------|---|----------|---------|
| GÜCÜ          | : | 2 x 84   | Watt    |
| VOLTAJI       | : | 198      | Volt DC |
| NOMINAL AKIMI | : | 2 x 0,42 | A       |
| YÜKÜ          | : | 630      | Kg      |
| TORKU         | : | 2 x 325  | Nm      |

**NMF.275 - MANYETİK FRENİN ÖZELLİKLERİ**

|               |   |          |         |
|---------------|---|----------|---------|
| GÜCÜ          | : | 2 x 84   | Watt    |
| VOLTAJI       | : | 198      | Volt DC |
| NOMINAL AKIMI | : | 2 x 0,42 | A       |
| YÜKÜ          | : | 800      | Kg      |
| TORKU         | : | 2 x 425  | Nm      |

Not : a ) 2:1 Askıda 30 metreden sonra denge zinciri kullanılmalıdır.

b ) Firmamız ürünlerinde haber vermeksizin değişiklik yapma hakkı saklıdır.

Notes : a ) Elevator balance compensation chain should be used when the distance is higher than 30 m

b ) We reserve the right to change the terms and conditions.