

**NMF.275 - MANYETİK FRENİN ÖZELLİKLERİ**

GÜCÜ	: 2 x 84	Watt
VOLTAJI	: 198	Volt DC
NOMİNAL AKIMI	: 2 x 0,42	A
YÜKÜ	: 630	Kg
TORKU	: 2 x 325	Nm

**NMF.275 - MANYETİK FRENİN ÖZELLİKLERİ**

GÜCÜ	: 2 x 84	Watt
VOLTAJI	: 198	Volt DC
NOMİNAL AKIMI	: 2 x 0,42	A
YÜKÜ	: 800	Kg
TORKU	: 2 x 425	Nm

Ø 320 x Ø 8,00 x 5 Halat

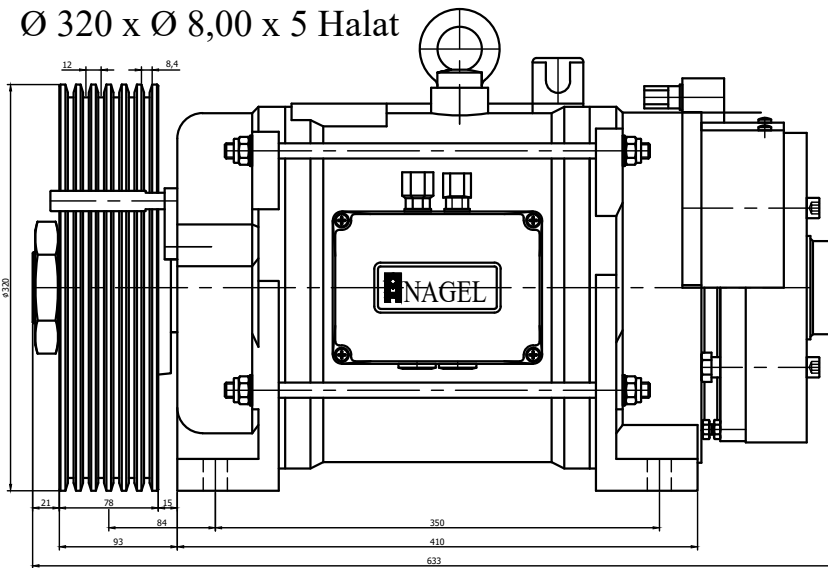

Ø 320 x Ø 8,00 x 6 Halat

Not : a ) 2:1 Askıda 24 metreden sonra denge zinciri kullanılmalıdır.

b ) Firmamız ürünlerinde haber vermeksizin değişiklik yapma hakkı saklıdır.

Notes : a ) Elevator balance compensation chain should be used when the distance is higher than 24 m

b ) We reserve the right to change the terms and conditions.