

NMF.300 - MANYETİK FRENİN ÖZELLİKLERİ

| | | | |
|---------------|---|-----------|---------|
| GÜÇÜ | : | 2 x 105 | Watt |
| VOLTAJI | : | 198 | Volt DC |
| NOMİNAL AKIMI | : | 2 x 0,530 | A |
| YÜKÜ | : | 1.275 | Kg |
| TORKU | : | 2 x 850 | Nm |

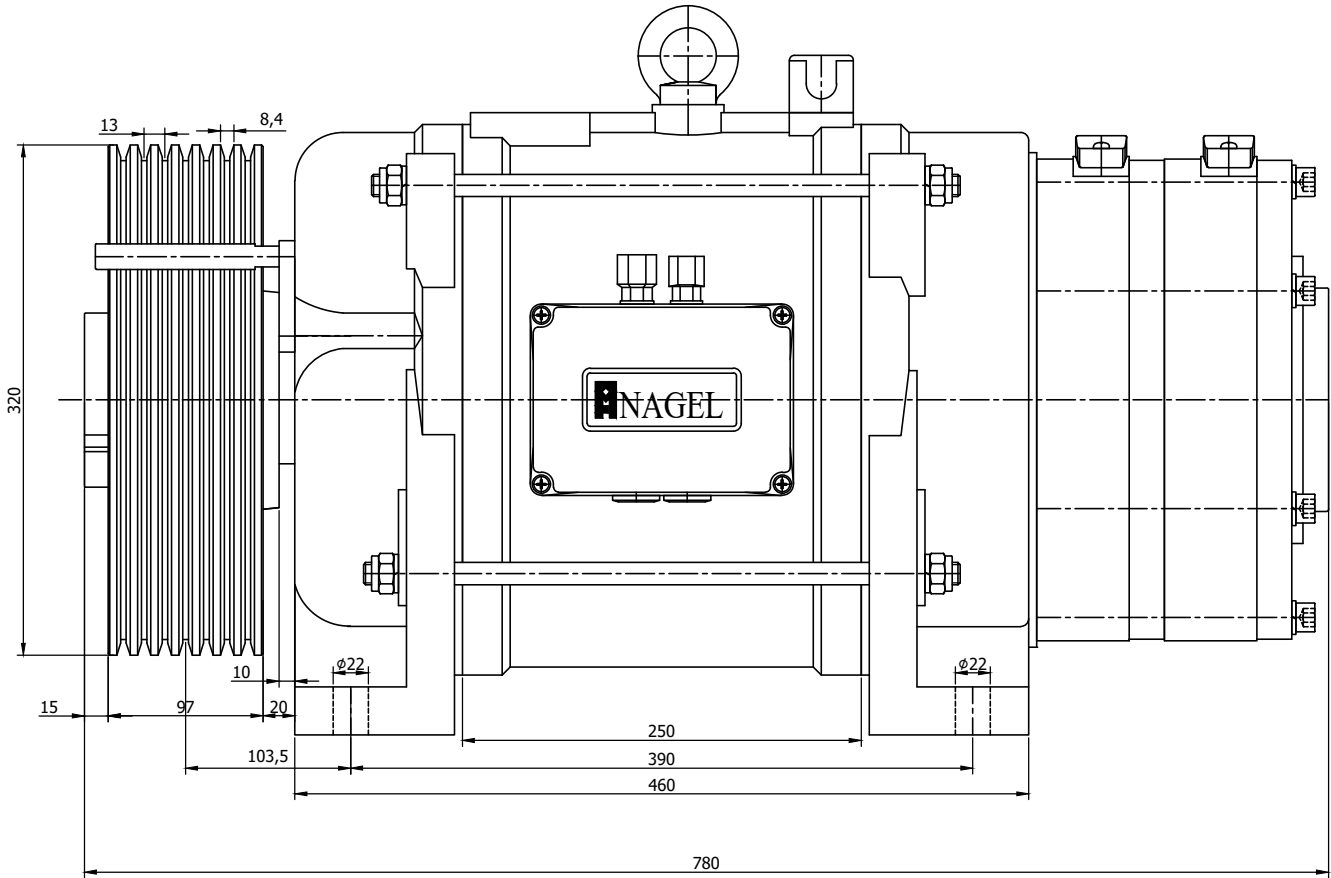

Not : a) 2:1 Askıda 24 metreden sonra denge zinciri kullanılmalıdır.

b) Firmamız ürünlerinde haber vermeksizin değişiklik yapma hakkı saklıdır.

Notes : a) Elevator balance compensation chain should be used when the distance is higher than 24 m

b) We reserve the right to change the terms and conditions.